

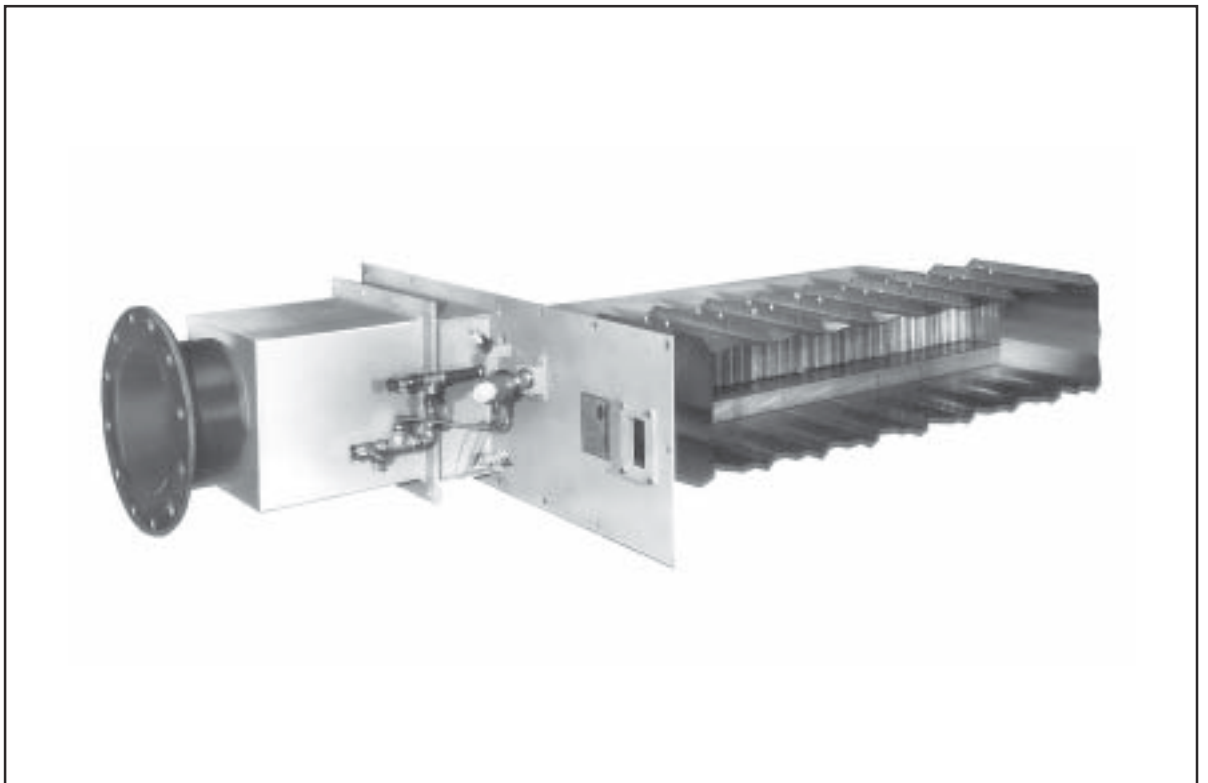

Minnox Burners

Version 1.0



COPYRIGHT

Copyright by Eclipse Combustion. All rights reserved worldwide. This publication shall not be copied, distributed, transmitted, transcribed or translated into any human or computer language, in any form or by any means, to any third parties, without the express written consent of Eclipse Combustion.

DISCLAIMER NOTICE

In accordance with the manufacturer's policy of continual product improvement, the product presented in this brochure is subject to change without notice or obligation.

The material in this manual is believed adequate for the intended use of the product. If the product is used for purposes other than those specified herein, confirmation of validity and suitability must be obtained.

We have made every effort to make this manual as accurate and complete as possible. Should you find errors or omissions, please bring them to our attention so that we may correct them. In this way, we hope to improve our product documentation for the benefit of our customers. Please send your corrections and comments to our Marketing Communications Manager.

LIABILITY AND WARRANTY

It must be understood that Eclipse Combustion's liability for its products, whether due to breach of warranty, negligence, strict liability, or otherwise, is limited to the furnishing of replacement parts and Eclipse Combustion will not be liable for any other injury, loss, damage or expenses, whether direct or consequential, including but not limited to loss of use, income of, or damage to material arising in connection with the sale, installation, use of, inability to use or the repair or replacement of Eclipse Combustion's products.

Any operation expressly prohibited in this Guide, any adjustment or assembly procedures not recommended or authorized in these instructions shall void the warranty



About this manual

AUDIENCE

This manual has been written for those persons who are already familiar with all the aspects of an air heat burner and its add-on components, also referred to as “the burner system”. These aspects are:

- design/selection
- installation
- use
- maintenance

The audience is expected to have previous experience with this kind of equipment.

MINNOX DOCUMENTS

Installation Guide No. 158

- This document.

Data 158

Bulletin 158C

RELATED DOCUMENTS

- Burner Programmer
- Ratio Regulator
- Control Actuator

REFERENCE INFORMATION

All requests for information, service or spare parts should include the burner model and serial number. For information contact Eclipse Combustion or your local Eclipse representative.

IMPORTANT NOTICES

- Read this manual carefully. Make sure that you understand the structure and contents of this manual.
- Obey all the safety instructions.
- Do not deviate from any instructions or application limits in this manual without written consent from Eclipse Combustion.
- If you do not understand any part of the information in this manual, do not continue. Contact your Eclipse sales office or Eclipse Combustion.

DOCUMENT CONVENTIONS

There are several special symbols in this document. You must know their meaning and importance.

The explanation of these symbols follows. Please read it thoroughly.



Danger:

Indicates hazards or unsafe practices which WILL result in severe personal injury or even death. Only qualified and well trained personnel are allowed to carry out these instructions or procedures. Act with great care and follow the instructions.



Warning:

Indicates hazards or unsafe practices which could result in severe personal injury or damage. Act with great care and follow the instructions.



Caution:

Indicates hazards or unsafe practices which could result in damage to the machine or minor personal injury. Act carefully.



Note:

Indicates an important part of the text. Read the text thoroughly.

HOW TO GET HELP

If you need help, contact Eclipse Combustion or your local Eclipse representative.

REFERENCE INFORMATION

All requests for information, service or spare parts should include burner model and serial number. For any information contact Eclipse Combustion or your local Eclipse representative.



Table of Contents

	About this manual	3
	Table of Contents	5
1	Introduction	7
	Product Description	7
	General	7
	Replacing the Burner	7
2	Safety	8
	Introduction	8
	Safety	8
	Capabilities	9
	Operator Training	9
	Replacement Parts	9
3	Burner Operation & Controls	10
	Introduction	10
	Gas Valve Train	10
	Control Principle	10
	Control Actuator	11
	Pilot Burner	11
	Flame Monitoring	11
	Combustion Blower Shut-Off	11
4	Installation	12
	Introduction	12
	Handling and Storage	12
	Approval of Components	12
	Pre-installation Checklist	13
	Installation	13
	Duct Configuration	14

5	Start Up & Adjustment	15
	Introduction	15
	Step 1: Initial Settings.....	15
	Step 2: Adjust Air Settings.....	16
	Step 3: Adjust the Pilot	17
	Step 4: Adjust Ignition load	17
	Step 5: Adjust High Fire	18
	Step 6: Adjust Low Fire	18
	Step 7: Verify the Settings & Shut Down the Burner	19
	Step 8: Verify gas settings	19
	Adjustment Data	20
6	Maintenance & Troubleshooting	21
	Introduction	21
	Maintenance	21
	Monthly Checklist	21
	Yearly Checklist	22
	Troubleshooting Guide Notes	23



Introduction

1

PRODUCT DESCRIPTION

The Minnox burner systems are designed for direct fired heating where negligible amounts of NOx and CO are required to fulfill legislative and process requirements. Emissions are less than 20 ppm NOx and less than 50 ppm CO (corrected to 3% O₂), making the Minnox burner the ideal heat source for industrial drying processes, the food industry and make-up air systems. Minnox burners are typically supplied as packaged units with the burner, mixer and supply manifold mounted into a duct section, or as a side-plate for insertion into the process ductwork.

Burner - The Minnox design includes a whirl-flame stabiliser for high excess air rates, up to 80%. The flame stabiliser also functions as a flame trap in order to prevent flash back situations. The pre-mixed gas/air mixture with the excess air results in a low flame temperature of about 1200°C. This provides an extremely low NOx discharge from the burner head.

Gas-Air Ratio Control - This is provided by a proportionator valve in the gas valve train.

Combustion Air Blower - The combustion air blower is selected for each individual application by Eclipse, and is supplied as a loose item for installation by the customer.

Valve Train - Valve trains are available in compliance with local codes.

Capacity Control - An automatic air control valve is mounted between the combustion air blower and the gas/air mixer.

Control Panels - Control panels are supplied in compliance with local codes.

GENERAL

The Minnox Burner has been designed and manufactured with high quality materials and care in workmanship. The instructions in this Guide have been prepared to ensure that, when followed, the burner will provide safe and efficient service.

Read and understand this entire manual before attempting to light the burner. This Guide will provide information for using, installing, controlling and adjusting this burner for its specific and limited purpose only.

REPLACING THE BURNER

Only qualified personnel, with adequate technical background, experience or training in this field of combustion equipment are allowed to install, maintain or adjust the burner.

Safety

2

INTRODUCTION

SAFETY

In this section, you will find important notices about safe operation of a burner system.



Danger:

The burners covered in this manual are designed to mix fuel with air and burn the resulting mixture. All fuel burning devices are capable of producing fires and explosions when improperly applied, installed adjusted, controlled, or maintained.

Do not bypass any safety feature.
You can cause fires and explosions.

Never try to light the burner if the burner shows signs of damage or malfunctioning.



Warning:

The burner and duct sections are likely to have HOT surfaces. Always wear protective clothing when approaching the burner.



Note:

This manual gives information for the use of these burners for their specific limited design purpose. Do not deviate from any instructions limits in this manual without written advice from Eclipse Combustion.



Note:

Read this entire manual before you attempt to start the system. If you do not understand any part of the information in this manual, then contact your Eclipse representative or Eclipse Combustion before you continue.

CAPABILITIES

Adjustment, maintenance and troubleshooting of the mechanical and the electrical parts of this system should be done by qualified personnel with good mechanical aptitude and experience with combustion equipment.

OPERATOR TRAINING

The best safety precaution is an alert and competent operator. Thoroughly instruct new operators so they demonstrate an adequate understanding of the equipment and its operation. Regular re-training must be scheduled to maintain a high degree of proficiency.

REPLACEMENT PARTS

Order replacement parts from Eclipse Combustion only.

Burner Operation & Controls

3

INTRODUCTION

This section defines the Minnox burner operating and control principle.

GAS VALVE TRAIN

Gas should be supplied to the burner inlet through a valve train which complies with all applicable local codes and standards.

CONTROL PRINCIPLE

Minnox burners are designed to operate with modulating temperature control systems. Gas - air ratio control is achieved by a ratio controller as shown in Figure 3.1.

Figure 3.1 Minnox Operation

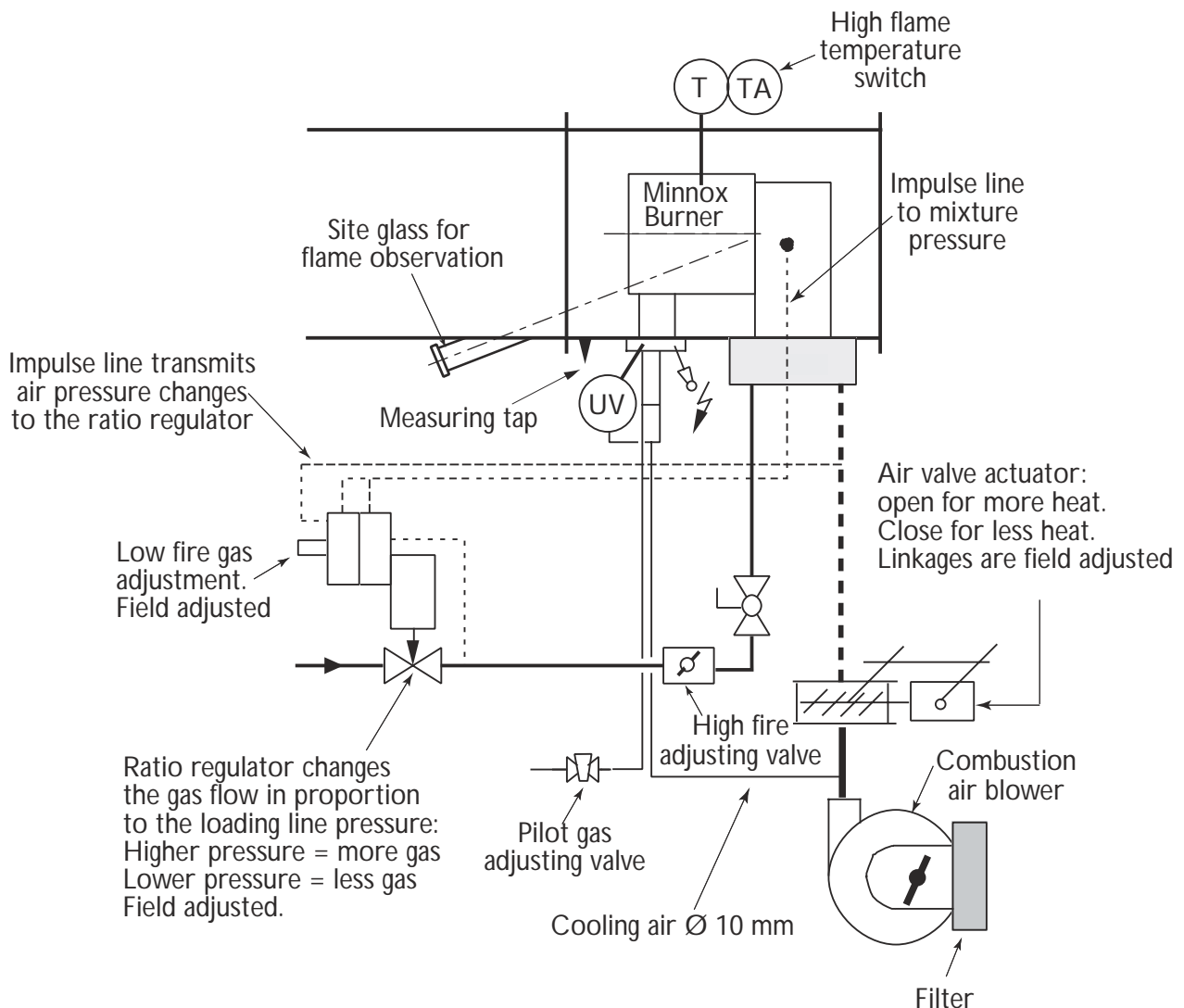

CONTROL ACTUATOR

The control actuator must have a 90° rotation and a minimum timing of 15 seconds at 90°.

PILOT BURNER

A spark ignited pilot is an integral part of each burner. An adjustable valve is included for pilot adjustment.

The pilot gas valve train should include at least a gas regulator and two solenoid valves.

If the combustion chamber pressure is likely to be more than 2,5 mbar (1" w.c.) or, if it is expected to fluctuate during operation, cross connect the regulator vent to the chamber.

FLAME MONITORING

A UV scanner is included with the burner. See pilot options Figure 3.2.

COMBUSTION BLOWER SHUT-OFF



Caution

During shutdown, the combustion air blower must not be turned off until the chamber temperature has dropped below 120° C (248° F). This is to prevent hot gases from flowing back through the burner and blower which will result in damage.

Figure 3.2 Pilot Options

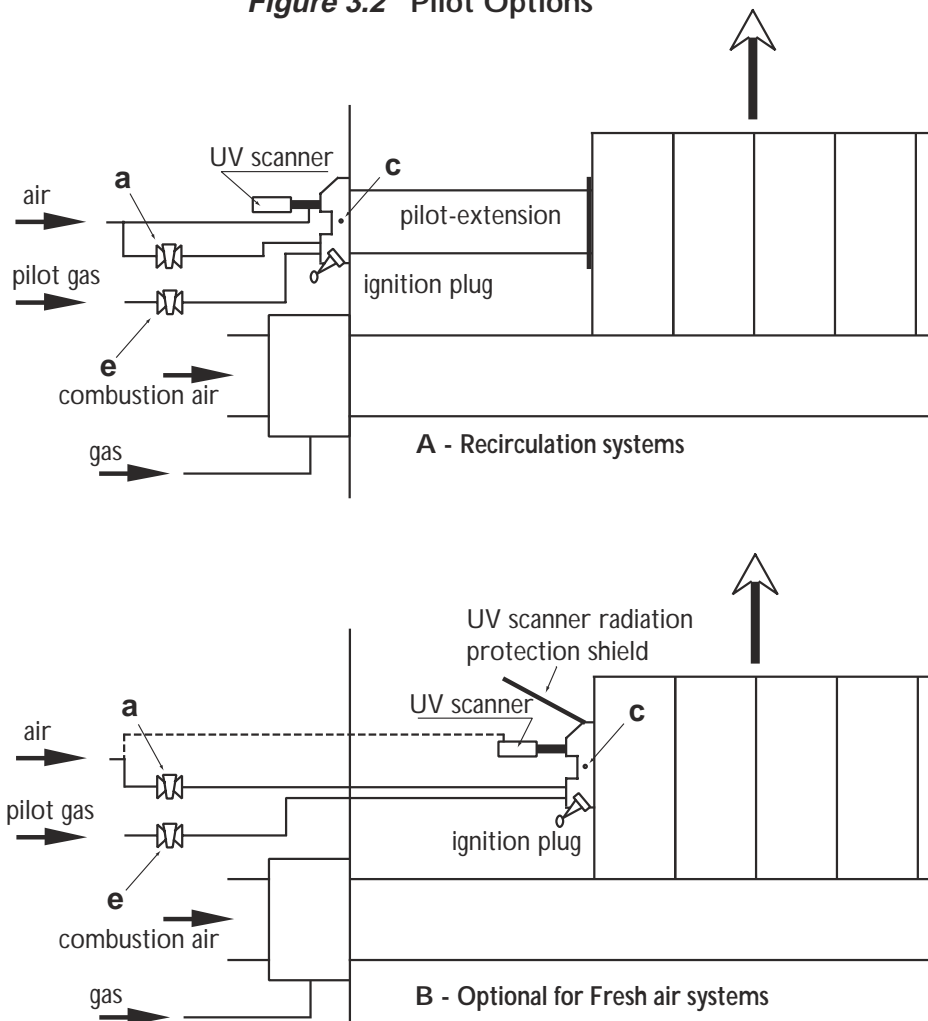



Installation

4

INTRODUCTION

In this section you will find the information and instructions that you need to install the burner system.

HANDLING AND STORAGE

Handling

1. Make sure that the area is clean.
2. Protect the components from the weather, damage, dirt and moisture.
3. Protect the components from excessive temperatures and humidity.

Storage

1. Make sure that the components are clean and free of damage.
2. Store the components in a cool, clean, dry room.
3. After you have made sure that everything is present and in good condition, keep the components in the original package as long as possible.

APPROVAL OF COMPONENTS

Limit controls and safety equipment

All limit controls and safety equipment must comply with all applicable codes and/or standards.

Electrical wiring

All electrical wiring must comply with all applicable codes and/or standards.

Gas piping

All gas piping must comply with all applicable codes and/or standards.

PRE-INSTALLATION CHECKLIST

INSTALLATION

Access

Make sure that you install the system in such a way that you can get easy access to the burner for inspection and maintenance .

Environment

Make sure that the local environment matches the original operating specifications. Check the following items:

- voltage, frequency and stability of the electrical power.
- type and supply pressure of the fuel.
- availability of enough fresh, clean combustion air.
- humidity, altitude and temperature of the air.
- presence of damaging corrosive gases in the air.
- adequate room ventilation in accordance with local codes for gas installations.

Duct configuration (see Fig. 4.1 page 14).

Combustion air blower

Blowers ordered from Eclipse are shipped loose for installation at job site. Locate the blower as close as possible to the burner and connect it with a pipe/duct, sized on a velocity of 10 m/sec. (33 fps).

Be certain that piping losses between the blower and burner are low enough to provide the required air supply pressures.
(see Data 158)

Blower wiring

Check that the motor is wired to rotate in the correct direction.

Combustion air pressure switch

Shipped loose for remote mounting.

Combustion air control valve

The air flow at the burner air connection flange should be evenly distributed. Never install the air valve closer than 10 pipe diameters from the burner without making special provisions.

Pilot gas valve train

The start gas valve train should be installed as close as possible to the burner mounted adjusting cock.

UV scanner

Use short pipe nipples to allow the best possible view of the flame.

Purge / cooling air for Pilot and UV-Scanner

A purge / cooling air supply is required. Minimum inside diameter 10 mm (.4").

Pressure taps

Install a pressure test point in the chamber wall for system pressure.

Sight glass

Install a sight glass to observe the flame pattern during burner operation. A major part of the flame must be visible. (see Fig. 3.1 page 10 for recommended position).

DUCT CONFIGURATION

Figure 4.1 Good Duct Design



Note:

The Minnox duct / side-plate unit has to be included in the process air duct system such that the velocity of the process air past the burner is as uniform as possible. The diagrams below indicate good design practice. The shaded areas represent the Minnox burner assembly.

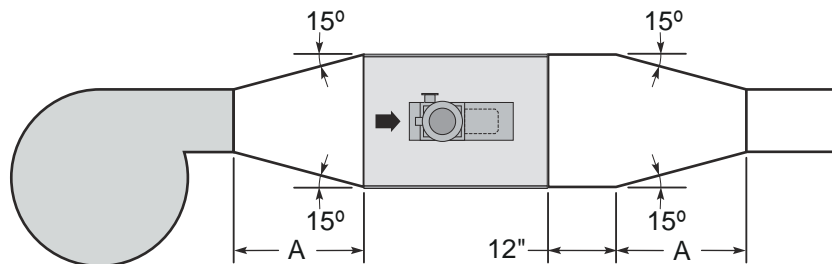
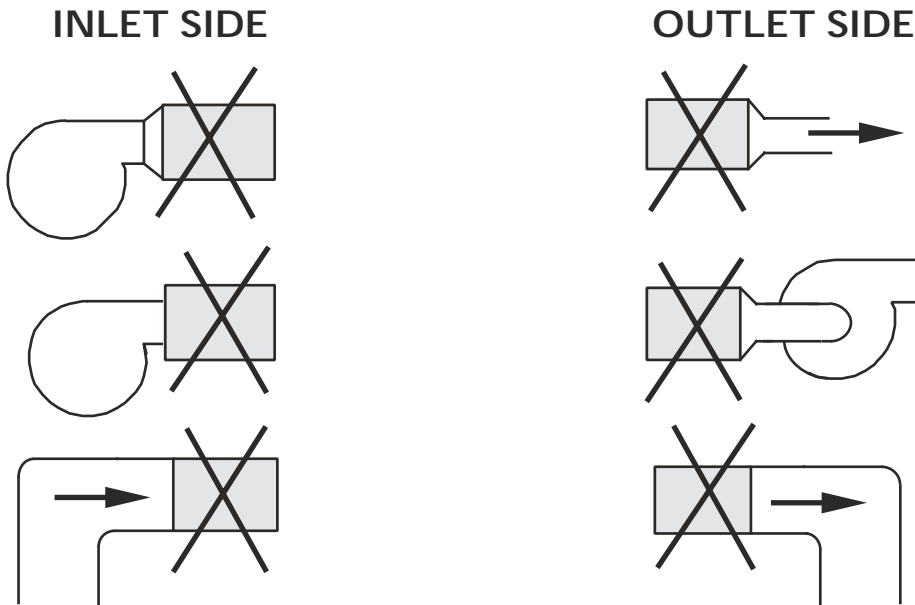

A is the length sufficient to provide a 15° taper

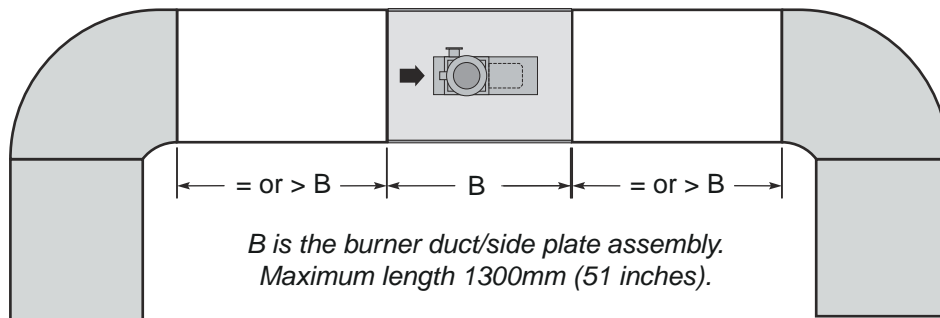

*B is the burner duct/side plate assembly.
Maximum length 1300mm (51 inches).*



Caution

Incorrect duct design can produce poor distribution both on and off the burner which in turn can create noise, vibration, temperature uniformity problems and possibly reduced burner life. The above diagrams are intended as a guide only. Inlet and outlet duct design is the responsibility of the customer. Eclipse can accept no responsibility for problems which may result from poorly designed ductwork.

Start Up & Adjustment

5

INTRODUCTION

This section describes how to start up and adjust the Eclipse Minnox burner system.

Danger:



The burners covered by this Guide are designed to mix gas with air and burn the resulting mixture. All gas burning devices are capable of producing fires and explosions if improperly applied, installed, adjusted, controlled or maintained.

Do not bypass any safety feature! Fire or explosion could result.

Never try to light a burner if it shows signs of damage or malfunction.

Step 1: Initial Settings

Gas valves

Close all manual and automatic gas valves, including the main gas butterfly valve and the pilot gas valve.

Combustion Air Blower

Start the blower and check the impeller for correct rotation. If it's running backward, have a qualified electrician change the motor wiring.

Combustion Air Pressure Switch

Adjust the pressure switch 20% lower than the measured pressure in high fire position of the air damper. Start and stop the blower and check if the switch actuates according the electrical diagram.

Gas Pressure Switches

Adjust the LOW gas pressure switch 20% lower than the pressure at valve train inlet.

Adjust the HIGH gas pressure switch 20% higher than the burner design pressure at high fire.

Cooling Air UV Scanners

Open the air adjusting tee one turn (see Fig 3.2 a page 11)

Circulating Fan

Start the fan to produce full process air flow past the burner.

Circulation (differential) Air Pressure Switch

Adjust the pressure switch 20% lower than the measured differential pressure. Start and stop the blower and check if the switch actuates according the electrical diagram and check the burner interlock system at too low air flows.

Step 2: Adjust Air Settings

During burner adjustment, you will need to run the control actuator on the air control valve to high and low fire several times. You may do this with the process temperature control, setting to a higher temperature for high fire or a lower temperature for low fire. It is also possible to use the manual override of the control actuator. Before attempting to adjust the burner, determine how you will control the actuator position and become familiar with the method.

Air Differential Pressure at Low Fire.

1. Run the control actuator to its low fire position.
2. Preset the low fire position at a differential air pressure of 1 mbar (.4" w.c.) between point A & D (see Fig. 5.1). Final adjustment can only be made during burner operation.

High Fire Air Adjustment

1. Run the control actuator to its high fire position. High fire position is obtained at about 85% opening of the air control valve.
2. Adjust the air differential pressure to 48 mbar (19" w.c.) by moving the inlet damper of the combustion air blower.
3. Set the limit switch on the control actuator. See the instructions of the control actuator to adjust the position limit switch.

Figure 5.1 Burner Adjustment and Settings

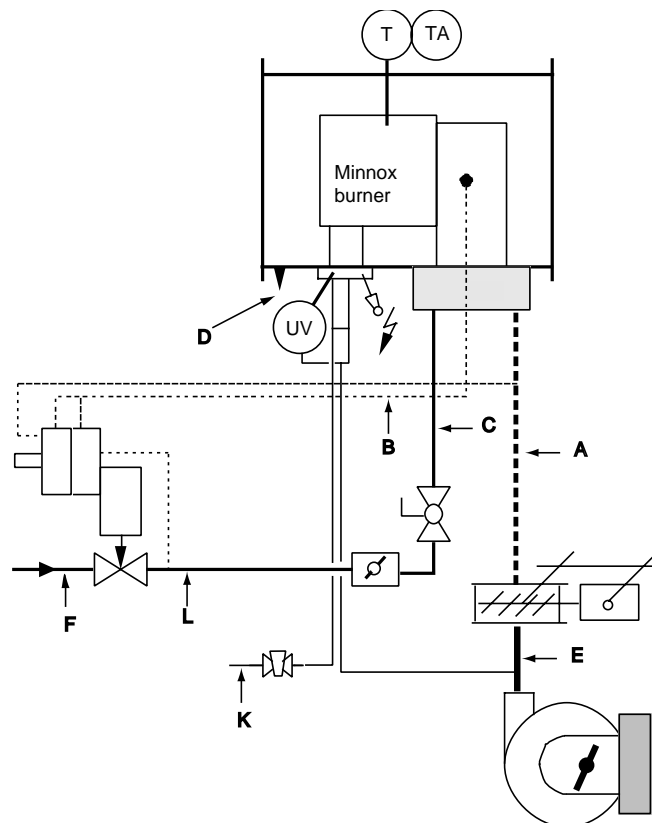

Step 3: Adjust the Pilot

Air Differential Pressure at Ignition Load Position.

1. Run the control actuator to its ignition load position.
2. Set the auxiliary switch on the control actuator to limit the actuator travel until ignition load position is obtained. For adjustment of this auxiliary switch refer to the instructions of the control actuator. Ignition load position is obtained at a differential air pressure of 4 mbar (1.6" w.c.), measured between taps A and D. (see Fig. 5.1 page 16).

Some electrical provisions may have to be made to operate only the pilot during pilot adjustment. See the literature included with the flame monitoring programmer and / or control panel for information on operation with pilot only.

1. Adjust the adjusting tee for pilot air and cooling air by fully opening the screw (see Fig 3.2 a page 11).
2. Adjust the adjusting screw (see Fig 3.2 c page 11) for pilot air by opening the screw 1 turn from closed position and lock the screw by fastening the lock nut.
3. Drive the control actuator to ignition load position and set the programmer to operate on pilot only.
4. Adjust the adjusting tee for pilot gas by opening the screw 2 turns from closed position (see Fig 3.2 e page 11).
5. Start the burner programmer.
6. Check for the presence of spark first.
7. Turn the gas screw inside the pilot gas adjusting tee counter-clockwise to increase flow, clockwise to decrease flow, until the pilot gives reliable ignition and a steady flame signal with minimum pilot gas flow.
8. Start the pilot several times to check reliable lighting.

Step 4: Adjust Ignition Load

1. Open the manual gas butterfly valve.
2. With the pilot lit and the control actuator in ignition load position, open the main automatic shut-off valve. The main flame should light.
3. Check if the flame fills up the entire burner surface.
4. The flame will be too rich. Throttle the manual gas butterfly valve until the UV flame signal starts to decrease (this adjustment is only possible by continuously observing the flame through a proper sight glass). The flame should be clear blue. Check the temperature on the limit controller (see Fig. 5.1 page 16). This temperature at ignition load should be approx. 250°C (480° F). The thermoelement should be inserted 30 mm (1.2") from burner plate. Check this dimension by removing the thermoelement and reinstalling 30 mm (1.2") through the insertion opening (see Fig. 5.2 page 18).

Step 5: Adjust High Fire

1. Run the control actuator to high fire position, meanwhile observing constantly the UV flame signal. When flame signal starts to lower and flame becomes too long and transparent increase the gas flow by opening the manual gas butterfly valve.
2. The flame should be clear blue. If the flame is orange and too short the gas flow is too high and the manual gas butterfly valve is opened too far.
3. Measure the gas differential pressure between taps C and D (refer to Fig. 5.1 page 16). Gas differential pressure at high fire (at approx. 48 mbar (19.2" w.c.) differential air pressure) is approx. 30 mbar (12" w.c.) on natural gas.
4. Set the burner to low fire.

Step 6: Adjust Low Fire

1. Make sure that the burner operates at low fire.
 ΔP air \sim 1 mbar (.4" w.c.).
2. When flame is too rich swirl plates start to glow and will be overheated. Readjust the spring in the ratio-regulator, turning the adjusting screw counterclockwise to decrease the gas flow. A high limit flame temperature switch will shut down the burner when flame temperature is above 550°- 600°C (1000°-1100° F).
3. When mixture is too lean the flame shows "holes" and the flame signal is unstable. Readjust the spring in the ratio-regulator, turning the adjusting screw clockwise to increase the gas flow.
4. Generate a steady flame detector signal of sufficient value.
5. Check the combustion air differential pressure.
6. Adjust the linkage between control motor and air control valve in such way that low fire position of the air control valve corresponds with the closed position of the control actuator.
7. Set the closed position limit switch on the control motor. Refer to the instructions of the control actuator.

After adjusting low fire flame return to high fire and observe the flame. Readjustment may be necessary (see Step 5).

Figure 5.2 Thermoelement detail

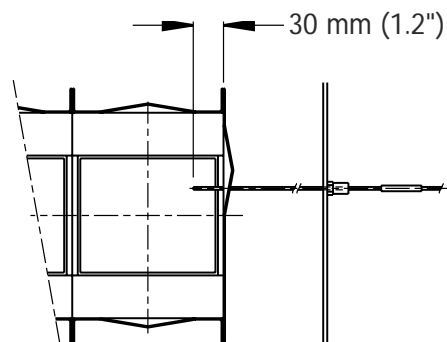

Step 7: Verify the Settings & Shut Down the Burner

1. Cycle the burner from high to low several times to check repeatability of settings and flame pattern. To make it easier to set up and troubleshoot the burner in the future, record your setup data (See Table 5.1 page 20).
2. Check the function of flame monitoring. Remove the UV-scanner. The main gas valves should shut down within about 1 second and system goes into flame failure.



Note:

If simulated limit or flame failures do not shut down the fuel system within an acceptably short period of time, immediately take the equipment out of service and correct the problem.

3. Check the function of the burner temperature limit switch by lowering the set point.
4. Check the high gas pressure switch by lowering the set point.
5. Check the low gas pressure switch by lowering the inlet gas pressure.
6. Check the function of the combustion air pressure switch by stopping the combustion air blower.
7. Check the maximum temperature of the UV-scanner. Increase cooling air if temperature exceeds 50° C (120° F).
8. Check the function of the process air pressure switch by stopping the process air blower.
9. Check the function of the process air temperature limit switch by lowering the set point.



Note:

Do not turn the blower off until the chamber temperature is below 120° C (250° F). This will prevent hot gases from flowing back through the burner and blower and damaging them.

10. Stop the burner

Table 5.1 Adjustment Data

	START POSITION	LOW FIRE	HIGH FIRE
Combustion air pressure Tap "E" above duct pressure			
Combustion air pressure drop between Tap "A" and chamber pressure Tap "D"	4,0 mbar 1.6" w.c.	1,0 mbar .4" w.c.	48 mbar 19.2" w.c.
Mixture pressure drop between Tap "B" and Tap "D"			
Gas pressure into mixer Tap "C"			
Gas pressure drop between Tap "C" and chamber pressure Tap "D" (Approx.)		0,3 mbar 0.1" w.c.	30,0 mbar 12" w.c.
Chamber pressure Tap "D"			
Gas pressure before proportionator Tap "F"			
Gas pressure out of proportionator Tap "L"			
Gas pressure into pilot gas adjusting cock Tap "K"			
Flame signal			
Burner surface temperature limit switch 550° - 600° C (1000° - 1100° F)			

Maintenance & Troubleshooting

6

INTRODUCTION

This section is divided into two parts:

- The first part describes the maintenance procedures.
- The second part helps you to identify problems that may occur, and gives advice on how to solve these problems.

MAINTENANCE

Preventative maintenance is the key to a reliable, safe and efficient system. The following are suggested guidelines for periodic maintenance. Burners in severe environments or operational conditions should be checked more frequently.



Note:

The monthly and yearly lists are an average interval. If your environment is dirty, then the intervals may be shorter. Check with local authorities having jurisdiction on their recommended maintenance schedules.



Caution:

Turn off power to burner and controls before proceeding with burner inspection.

Monthly Checklist

1. Inspect flame-sensing devices for good condition and cleanliness.
2. Test all alarms for proper signals.
3. Check ignition spark electrode operation and check proper gap.
4. Check all valve actuators and control valves for free, smooth action and adjustment.
5. Test interlock sequence of all safety equipment and manually make each interlock fail, noting that related equipment closes or stops as specified by the manufacturer. Test flame safeguard by manually shutting off gas to burner.
6. Test all manual fuel valves for operation.
7. Check filters on main air fan for cleanliness.
8. Check gas filter or strainers.

Yearly Checklist

1. Test (leak test) safety shut-off valves for tightness of closure.
2. Test pressure switch settings by checking switch movements against pressure settings.
3. Visually check ignition cable and connectors.
4. Check all pipe connections for leaks.
5. Check air ducting connections for leaks.
6. Check mixture ducting connections for leaks.
7. Check all bolts and screws for tightness.
8. Check the area around the burner mounting flange for signs of overheating. Gasket or insulation replacement may be necessary.

TROUBLESHOOTING GUIDE NOTES

PROBLEM	POSSIBLE CAUSE	SOLUTION
Burner sequence starts but locks out before ignition.	Combustion air fault • Blower failure	Check blower and remedy fault.
	Combustion air fault • Blocked blower inlet or filter	Clean inlet. Clean or replace filter
	Combustion air fault • Pressure switch failure	Check pressure switch and replace if necessary
	Combustion air fault • 3 way solenoid valve failure (if fitted)	Check solenoid valve. Replace coil if necessary.
Burner start up sequence runs but pilot does not light.	No ignition: • There is no power to the ignition transformer.	Restore power to the ignition transformer.
	No ignition: • Open circuit between the ignition transformer and the ignition electrode.	Repair or replace wiring to the ignition electrode.
	No ignition: • The ignition electrode needs cleaning.	Clean the ignition electrode.
	No ignition: • The ignition electrode is not properly grounded to the burner.	Clean the threads on the ignition electrode and the burner.
	No ignition: • Ignition electrode insulator is broken.	Inspect the ignition electrode and replace if broken.
	Not enough gas: • The gas pressure is too low.	Check for sufficient gas pressure.
	Not enough gas: • Pilot solenoid valve not opening.	Check wiring
	Not enough gas: • Pilot adjustable limiting orifice valve set too low.	Adjust flow rate
Burner main flame does not light or goes out as control actuator runs to high fire.	Not enough gas: • Insufficient pressure into or out of ratio regulator.	Check for sufficient gas pressure. Check ratio regulator. Outlet differential pressure should be equal to the loading line pressure.
	Not enough gas: • Manual gas adjusting valve not open enough.	Open manual gas adjusting valve until a stable flame is achieved.
	Not enough gas: • Low fire setting too low	Adjust the low fire setting

PROBLEM	POSSIBLE CAUSE	SOLUTION
Burner lights and then goes to lockout.	No flame signal: <ul style="list-style-type: none"> • Dirty UV scanner lens 	Measure flame signal. Inspect and clean sensor. Replace if necessary
The high fire flame is large and yellow.	Insufficient combustion air pressure: <ul style="list-style-type: none"> • Air damper closed. • Blower running in reverse. • Inlet or filter blocked. 	Set air damper correctly. Check and correct blower wiring. Clean inlet or filter. Replace filter if necessary.
	Gas pressure too high: <ul style="list-style-type: none"> • Pressure regulator adjustment set too high. 	Adjust pressure regulator
The low fire flame is weak and unstable.	<ul style="list-style-type: none"> • Insufficient gas flow to the burner. 	Adjust the low fire setting on the modulating control actuator.
Burner behaves erratically or does not respond to adjustment.	<ul style="list-style-type: none"> • Burner internals loose, dirty or burned out. 	Contact Eclipse for service.
Swirl plates become red in colour.	<ul style="list-style-type: none"> • Overheating due to gas / air mixture too rich 	Adjust gas / air mixture. See
Cannot initiate a start up sequence.	<ul style="list-style-type: none"> • Combustion air pressure switch has not made "No air" contact. 	Check air pressure switch adjustment. Check air filter if fitted. Check blower rotation. Check outlet pressure from blower.
	<ul style="list-style-type: none"> • External interlock failure 	Check all external interlocks.
	<ul style="list-style-type: none"> • High gas pressure switch has activated 	Check pressure switch settings.
	<ul style="list-style-type: none"> • Malfunction of the burner programmer. • No power supply to the burner programmer. 	Have a qualified electrician troubleshoot and correct the problem.



Eclipse Combustion



Offered By:

Power Equipment Company
2011 Williamsburg Road
Richmond, Virginia 23231
Phone (804) 236-3800
Fax (804) 236-3882

www.peconet.com